

## PARTS

- A. Tablet / Phone Arm Assembly
- B. Phone Mount
- C. 1 x 4mm Allen Key (WRP-B741)
- D. 1 x 5mm Allen Key (WRP-B740)
- E. Threadlocker Compound

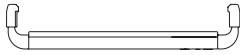

B

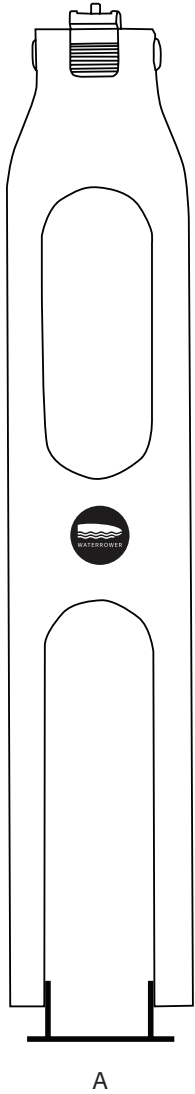
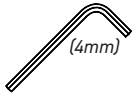

C

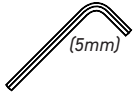

D



E



If you have any questions or comments about installing your Tablet / Phone Arm, please contact [support@waterrower.com](mailto:support@waterrower.com).

WATERROWER USA  
560 METACOM AVE.  
WARREN, RI 02885  
WWW.WATERROWER.COM  
TEL: 800 852 2210



## VR3 ROWER TABLET / PHONE ARM ACCESSORY



# INSTALLATION PROCESS

## STEP 1

Using the provided 5mm Allen key (D), loosen both upper black Joint Connector Nuts (JCNs) on the forward riser of the tank assembly approximately 3 full turns. *It is not necessary to fully remove the JCNs.*

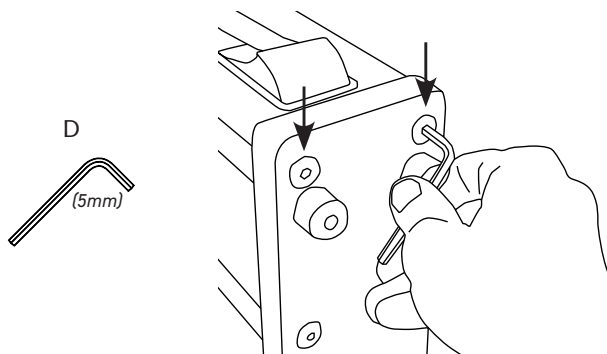

## STEP 2

Remove the Tablet / Phone Arm assembly (A) from the box and unwrap it. Lay the arm flat on the top deck of the tank assembly with the arm's embedded magnets facing down. Carefully slide the arm's bracket under / onto the JCNs loosened in Step 1, ensuring the interior surfaces of the bracket are in contact with the face of the forward riser. Using the 5mm Allen key (D), fully tighten both JCNs to secure the bracket in place.

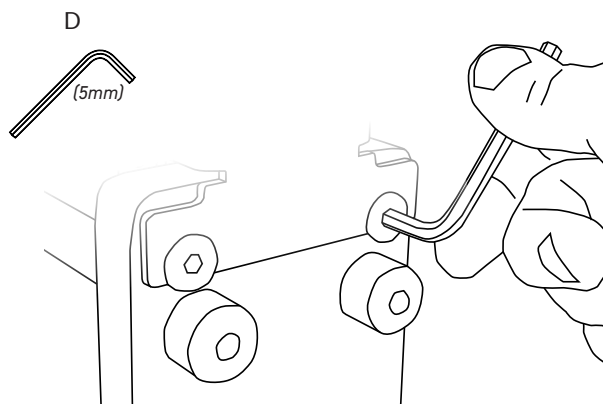

## STEP 3

Attach the phone mount (B) to the arm's ratchet by screwing it on.

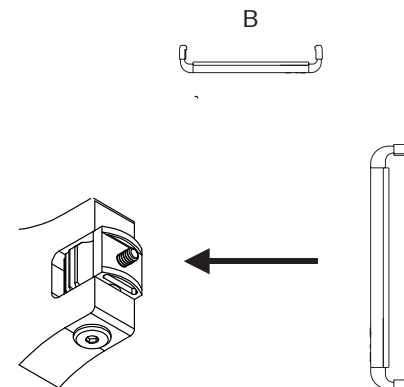

## WHAT IF THE ARM LOOSENS?

Your Phone / Tablet Arm's connection to its bracket may loosen after repeated use or as a result of humidity affecting the arm's wood. To rectify this, follow the steps below.

### STEP A

While holding the inner black JCN steady with the 5mm Allen key (D), use the 4mm Allen key (C) to remove the outer black Joint Connector Bolt (JCB).

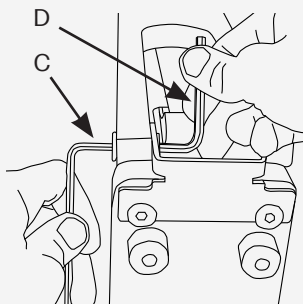

### STEP B

Using scissors or a knife, cut the tip off the threadlocker applicator bottle (E). Apply a small amount of threadlocker compound to the threads of the JCB removed in Step A. Reinstall the JCB finger-tight.

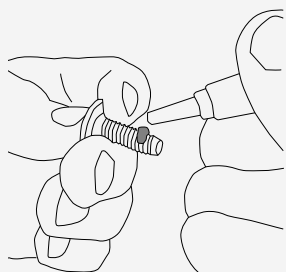

### STEP C

While holding the JCN steady with the 5mm Allen key (D), use the 4mm Allen key (C) to snugly tighten the JCB.

### STEP D

Repeat Steps A-C for the other JCB.

### STEP E

Allow the threadlocker compound to cure for about 20 minutes before using the arm again.

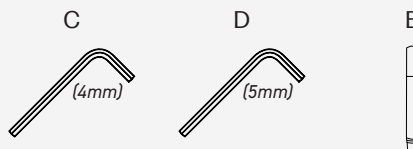

## USING THE ARM

To raise the arm to viewing position, simply rotate the arm upwards until both kickstands activate, then lower the arm until the kickstands rest on the rower's top deck. Lift the top of the phone mount and insert your mobile device. Rotate your device to a comfortable viewing angle.

## STOWING THE ARM

### STEP A

Remove your device from the holder, then rotate the device holder backwards so it lays flat on top of the arm.

### STEP B

To lower the arm to storage position, rotate the arm upwards, then depress both kickstands with your fingers while simultaneously lowering the arm. The arm's magnets will secure it in place when lowered.

*Do not attempt to move or store your rower with the device arm in usage position or with your mobile device attached.*