

DOMYOS | 
BY | **WaterRower**®

OWNER'S MANUAL

TABLE OF CONTENTS

Welcome	02
Assembly Manual	03 – 07
The Water Tank	08 – 09
PD App Instructions	10 – 16
Warranty Information	21

INTRODUCTION

Congratulations on purchasing a DOMYOS | WaterRower® WR3 indoor rowing machine!

The WR3 uses the effect of water-drag to provide a realistic on-water rowing experience. Simply choose your intensity by altering the pace and power at which you row. The more force you apply, the greater the drag and the harder the workout.

This owners guide has been designed to provide you information on the assembly, operation and maintenance of your WR3.

Please review the entire manual before beginning your rowing fitness.

Enjoy the row!

Consumer Safety: Please consult a physician before starting out with an exercise program.

We have designed the WR3 to ensure simple assembly. The rower comes partially assembled in two boxes. Assembling your rower takes approximately 30-45 minutes; the only tool required is a 5mm Allen Key that is included on the rear spacer.

PLEASE READ INSTRUCTIONS FULLY BEFORE STARTING ASSEMBLY

COMPONENTS

Primary Parts

- A Rails x 2
- B Rear Spacer with Bungee and JCN (WRP-B700) x 4 attached
- C Seat
- D Footboard
- E Tank Assembly

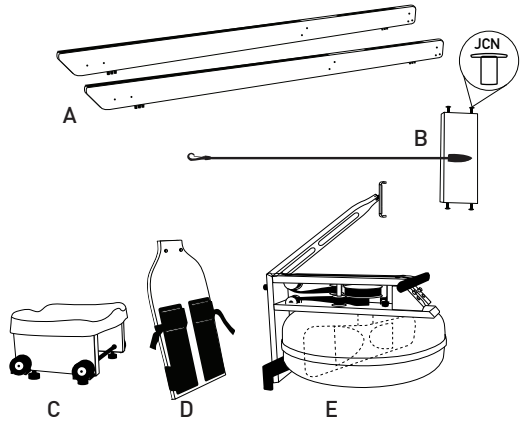

Ancillary Parts

- F Dolly Wheel Assembly (WRP-D100) x 2
- G JCB (WRP-B711) x 8
- H Handle Rest (WRP-P430) x 2
- I Handle Rest Bolt (WRP-P455) x 2
- J 5mm Allen Key (WRP-B740) x 1
- K Footpads (WRP-P700) x 2
- L Syphon Pump (WRP-B405) x 1
- M Purification Tablets (WRP-B960) x 2

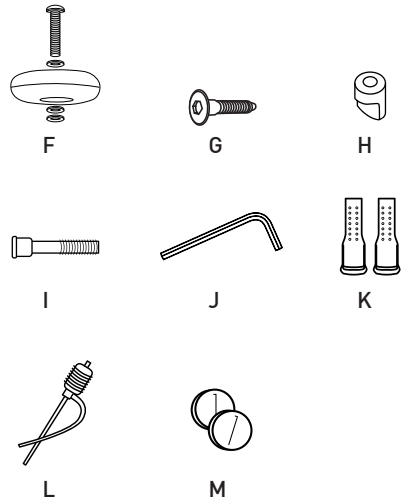

STEP 1

Using the Allen Key (J) provided, unscrew the JCN Nuts from the rear spacer.

Allen Key

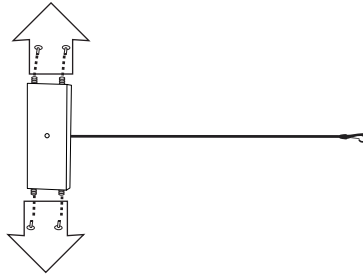

STEP 2

Lay the rails (A) on the floor and connect the rear spacer (B) using the female JCN nuts and the Allen Key (J) provided. Note: With rubber feet down.

Allen Key

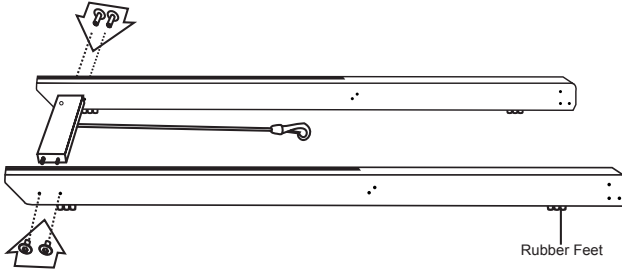

STEP 3

Place the seat assembly (C) between the rails (A) with the indent facing towards the rear spacer (B). The larger vertically mounted wheels (the load wheels) should sit on the plastic extrusions on the top of the rail. The smaller horizontal wheels below the seat (the guide wheels) should sit between the rails. It may be necessary to separate the rails slightly to allow the guide wheels to fit down between the rails.

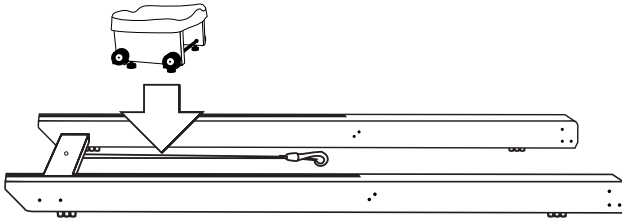

STEP 4

Place the tank assembly between the rails.

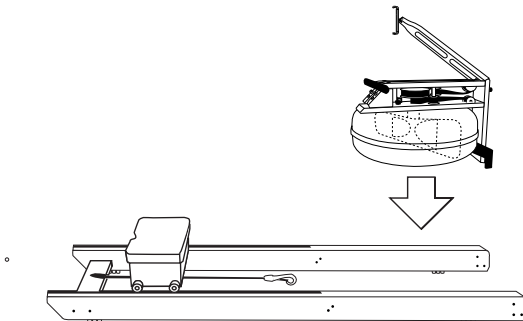

STEP 5

Using the Allen Key (J), screw the JCB Bolts (G) into the pre-installed threads attaching the tank to the rails at location 1 on both, left and right rail; tighten until snug.

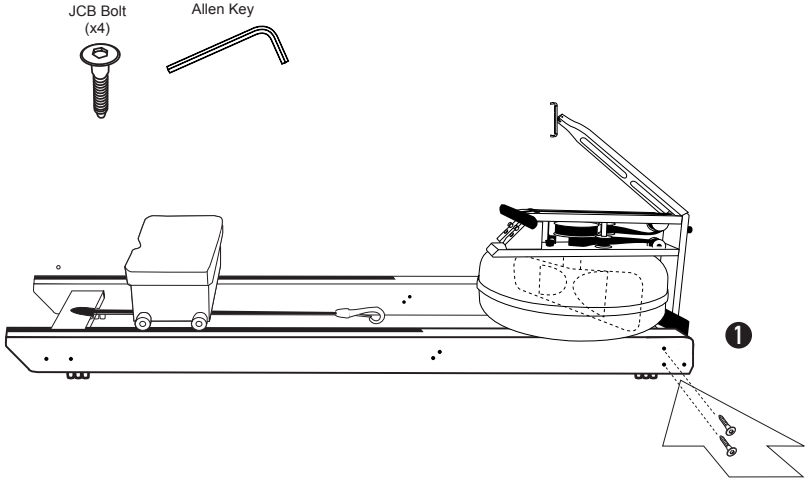

STEP 6

Place the footboard (D) between the rails (A), positioning the top two holes over the two threaded holes in the tank unit. Using the JCB Bolts (G), attach the footboard (D) to the rails at location 1. Screw the Handle Rests (H) into position using the Handle Rest Bolts (I) at location 2; do not over tighten.

*Should you experience any problem with aligning the components, loosen all the fasteners, align and re-tighten.

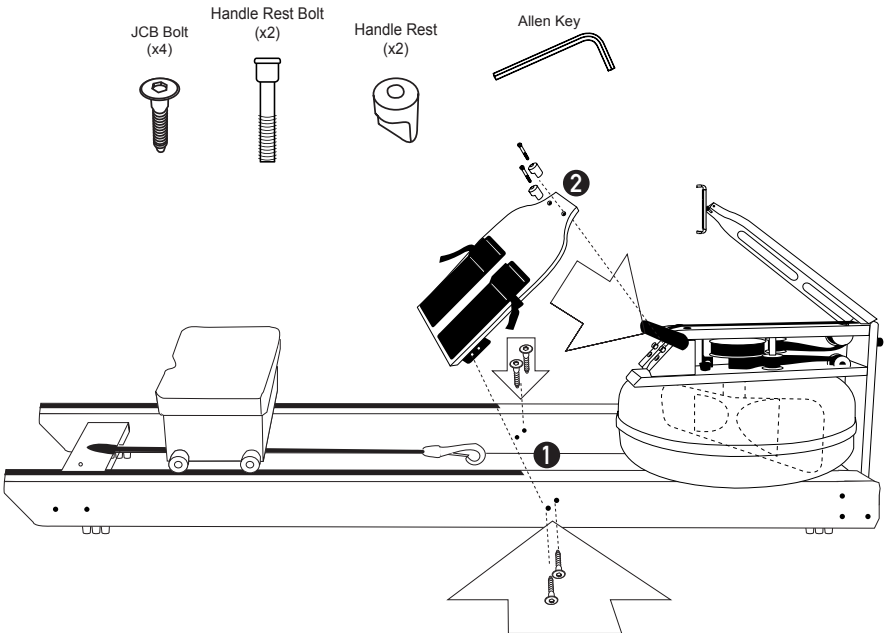

STEP 7

Slide the footpads (K) underneath the footpad cover plate. Use a flat head screw driver to lift the footpads up and over the lip of the cover plate. The footpads can be adjusted by lifting the top lip of the footpad up to unhook it and repositioned on another hole; adjust as necessary.

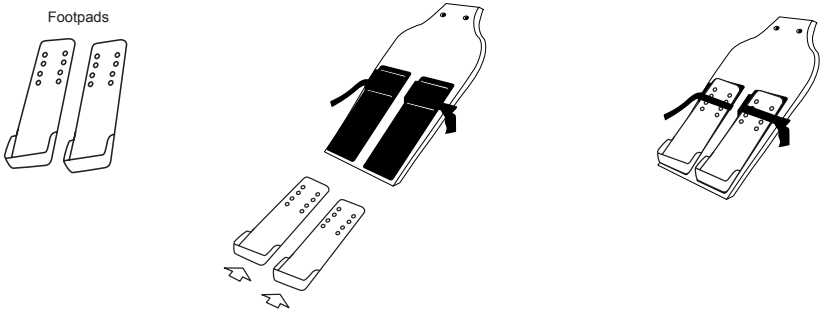

STEP 8

Using the Allen Key (J), affix the Dolly Wheel Assembly (F) to the rail in the order shown and tighten. Note: wheel goes on the outside of the rail.

Allen Key

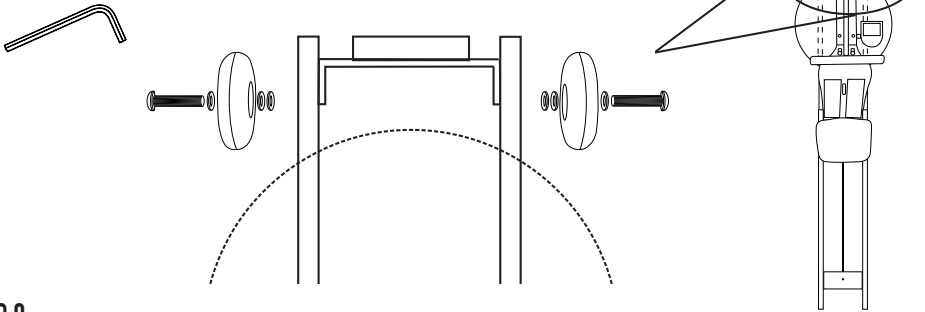

STEP 9

Stand the rower upright. Release the recoil belt, which is wrapped around the bracket at the base of the machine. Ensure that the recoil belt is passing over all guide pulleys. Connect the bungee to the recoil strap by hooking the bungee hook through the recoil belt D-ring.

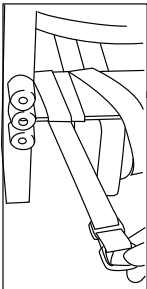

Release

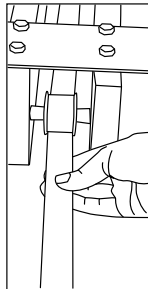

Check Pulley

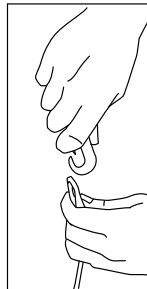

Connect

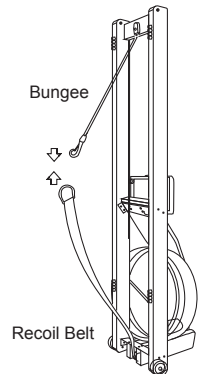

Bungee

Recoil Belt

STEP 10

Before filling the tank and rowing, lay rower flat and pull handle bar to ensure that the recoil belt passes smoothly over all pulleys.

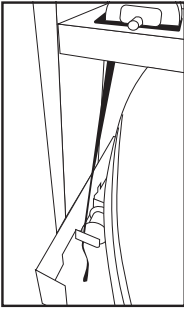

Misaligned

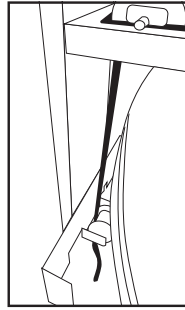

Aligned

BATTERY REPLACEMENT

Remove both handle rest bolts at location 1, remove top JCB bolt attaching rail to footboard on each side at location 2. Pivot footboard forward 4-6" allowing access to AA batteries (N) in battery holder underneath top deck between the key brackets. Replace batteries and reinstall footboard.

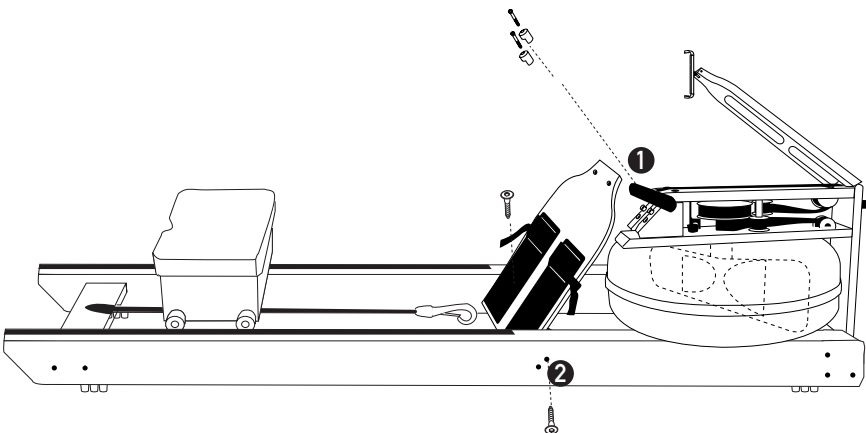
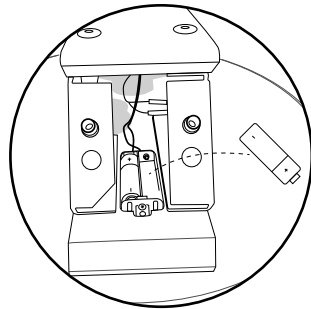
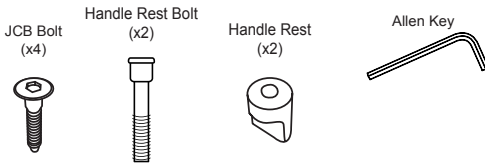

STEP 1

Download App from App Store

**STEP 2**

Turn on bluetooth by pressing button on side of top deck

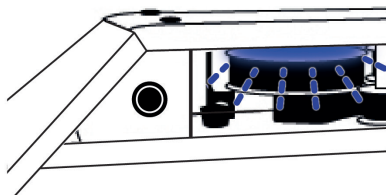
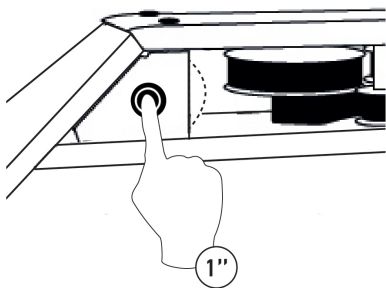
**STEP 3**

Open App

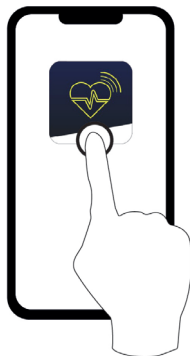

STEP 4

Find your device and connect

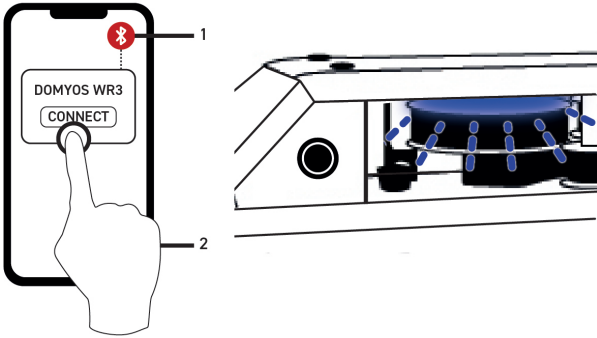

STEP 5

Allow up to 30 seconds for pairing to complete

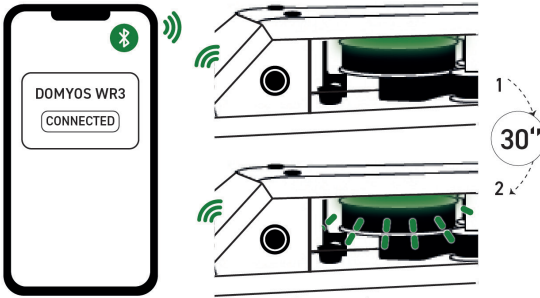

STEP 6

Once paired begin your rowing session

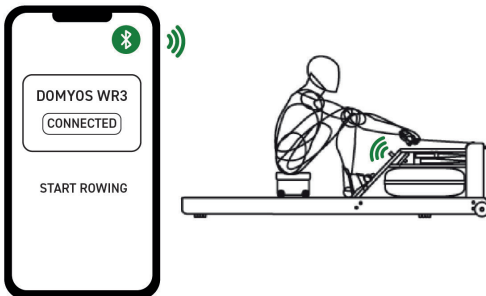

WATER LEVEL

The Level Gauge is positioned on the side of the tank. Information on the sticker includes Domyos I WaterRower® WR3 contact information and the Water Level Gauge. The maximum level to fill the tank is Level 19. **DO NOT** fill above the maximum level - this could void the warranty. The advised water level is 16-18.

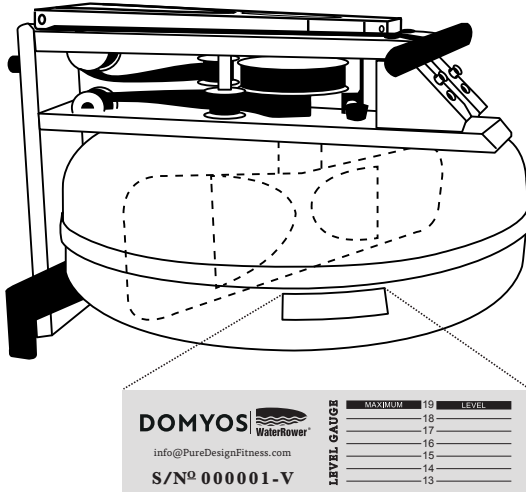

WATER SOURCE

Fill the tank with municipal or distilled water. Municipal water contains additives which will deter the initial growth of algae. Distilled water removes many of the natural minerals and microbes, improving the initial water purity. Due to its high mineral levels refrain from using well water.

PURIFICATION TABLETS

The water must be refreshed periodically by adding a Purification Tablet, provided in your owners kit. The purification tablet degrades by exposure to light: this may vary from 3 months in direct sunlight to 2+ years in an artificially lit setting. On average, we advise adding 1 purification tablet every 6 months.

If water discoloration occurs prematurely, add one tablet immediately. If the water does not clear, we recommend emptying the tank, flushing it out with clean water, refilling and adding a purification tablet.

The use of alternative cleaning products in the tank, beyond those provided by Domyos I WaterRower®, is prohibited. Adding such products may void your warranty.

For additional tablets please go to www.support.decathlon.fr

HOW TO FILL AND EMPTY THE TANK

- 1) Remove the tank stopper from between the top and bottom deck.
- 2) Use the provided syphon pump (L), or a hose if available, to fill the tank to the desired level (reference page 08) with municipal or distilled water. To pump water, turn the knob clockwise to close valve as shown in figure 2
- 3) Place water source above (higher than) water destination:
 - See Figure 3 for filling tank
 - See Figure 4 for emptying tank
- 4) Squeeze pump 4-5 times until water flows
- 5) Turn knob counter-clockwise to allow air into the pump and end syphon
- 6) Insert one water tablet (M) now and every three to six months, henceforth. Additional purification tablets are available upon request at: www.support.decathlon.fr

Once completed, insert the tank stopper; it may be necessary to moisten the stopper to assist with replacement. Please wipe excess water from all components after filling.

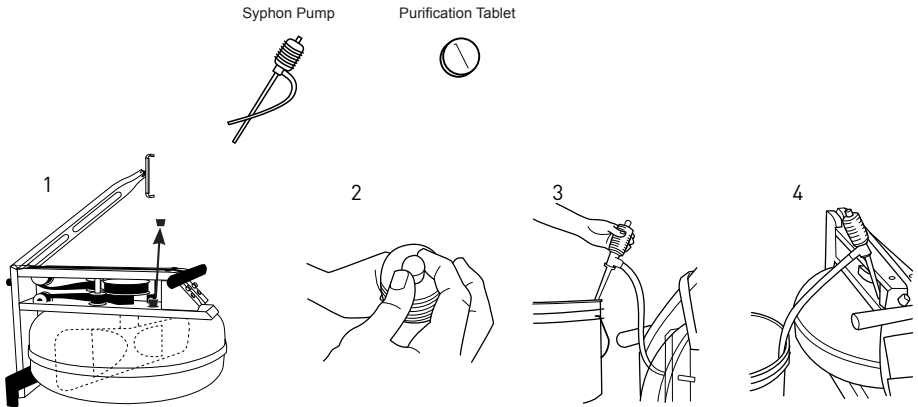

WATER RESISTANCE

The DOMYOS I WaterRower® WR3 is unique in using the effect of water-drag to provide an exercise which is entirely self-paced. Because drag is linked to speed, a crew rowing down the river chooses its intensity of exercise simply by altering the pace at which they row. The faster the boat travels, the greater the drag and the harder the crew must work. Our design removes the need for external adjustments to change resistance; if a more challenging workout is desired, simply row faster and with more power; the rower will respond accordingly.

SAFETY

Please consult a physician before beginning your workouts.

WARNING:

- ⚠ Please keep hands away from moving parts when rowing machine is in use.
- ⚠ Keep all observers, especially children and pets, away from moving seat wheels, straps and pulleys.
- ⚠ Place the handle back into the handle rest after use; do not let go of the handle while rowing.
- ⚠ When the VR3 is in its upright storage position, take care it is not bumped which may cause it to fall over; take extra caution with children.
- ⚠ Do not pull on the handle when the WR3 is upright; this may cause the VR3 to fall over. NOTE: Only those that can comfortably store and move the VR3 should have access to the rower, when in standing position.

STORAGE

The WR3 has been designed for compact storage when not in use. To stand the WR3 up, slide the seat towards the footboard, lift the rear leg and roll the machine towards you, using the momentum to stand it upright. When stored, the WR3 is stable and only takes up the space of a chair.

Dimensions:

22" / 56CM wide, 82" / 208CM long, 21" / 53CM tall

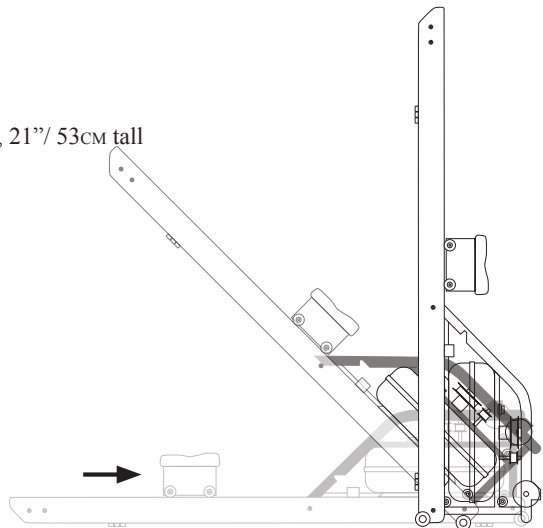

PREVENTATIVE MAINTENANCE

To ensure peak performance of your DOMYOS | WaterRower® WR3 for many years to come, we advise following the preventative maintenance schedule.

2-4 WEEKS

- Check the alignment of the recoil and handle belts. If a belt is off its pulley, the recoil of the handle will be sluggish and not feel smooth; this can also lead to fraying of the belt. To realign, reduce tension by placing handle at front of machine, then realign belt on pulley.
- Inspect the bolts along the tank assembly and rail assembly to ensure they are all secure in the frame of the rower. If necessary, use a 5mm allen key to tighten any bolts that have come loose.
- We suggest you clean your rower as you would any other piece of furniture in your home. Regularly clean the VR3 with a soft cloth, dampened with water and antibacterial dish soap diluted.

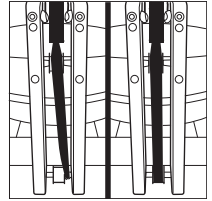

3-6 MONTHS

- Add 1 purification tablet to the water. Be sure to replace tank stopper after inserting tablet.
 - *See page 8 for more info and to obtain more tablets.
- Review the stitching and wear on all straps. If you notice excessive wear please contact us at <https://support.decathlon.fr> to review support options.
- Check the recoil tension; ensure the handle returns smoothly to the front of the machine when rowing, should handle return be less than desired please contact <https://support.decathlon.fr> for troubleshooting and/or replacement.

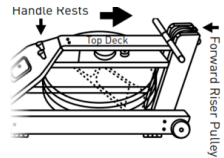
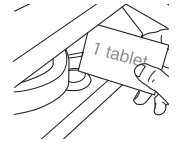

6-12 MONTHS

- As with any furniture, wood elements require oil to keep its luster and shine. We recommend using Danish Oil to maintain the wood.
- The monitor runs on 4 AA batteries. To replace monitor batteries, remove back monitor cover by unscrewing the two screws on the top and bottom of the computer with a Phillips Head screwdriver.

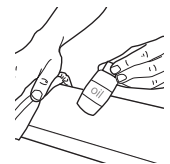

Following proper rowing technique will allow you to get the best of your WR3.

The rowing action has been broken down into 3 phases and 3 positions to make it easier for you to learn the technique and we hope it will soon become second nature.

Position 1: The Release Position

The Release Position is at the end of the Drive Phase. Your legs are straight, the handle is drawn into your chest, the upper back is leaning back just passed being vertical, shoulders are relaxed and your eyes are looking forward.

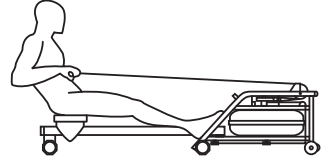

Phase 1: The Rock Over Phase

The Rock Over Phase begins at the Release Position and ends at the Rocked Over Position. Your arms extend and your torso rocks over on the seat at the hips, not the lower back. Your legs remain straight.

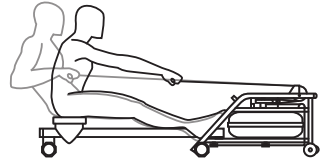

Position 2: The Rocked Over Position

In the Rocked Over Position, your arms are straight, posture is tall and strong. Your legs remain straight.

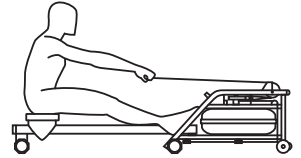

Phase 2: The Recovery Phase

The Recovery phase begins at the Rocked Over Position and ends at the Catch Position. As the name suggests, it is the recovery part of the rowing stroke. There is no active propulsion. The legs bend and slide the body forwards to the Catch Position. The arms remain stretched out straight in front.

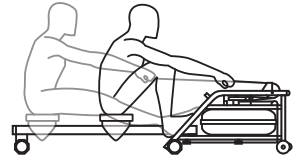

Position 3: The Catch Position

The Catch Position is when your body is coiled like a spring and ready to release. Your legs are bent with the seat as close to your heels as comfortable for you. Your arms and upper body are reaching forward and eyes are looking straight ahead.



Phase 3: The Drive Phase

The Drive Phase is the work phase of the rowing action beginning at the Catch Position and ending at the Release Position. You first push with the legs, hold your posture strong and complete the Drive Phase by pulling the handle into your body. End at the Release Position.

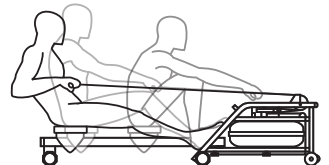

WARRANTY (COVERS PRIVATE AND NON-COMMERCIAL USE)

The DOMYOS I WaterRower® WR3 has been designed for domestic use and is not intended for commercial use. It should therefore only be used in a domestic setting.

WATERROWER will replace or repair at its factory or an authorised service centre any component found to be defective due to faulty materials or workmanship for one year from the date of original shipment or retail purchase. The original purchase receipt must be kept in order to provide proof and date of purchase. No warranty claim shall be met without proof and date of purchase.

This warranty shall be void if WATERROWER deems the non-conformity claim to result from (a) any accident, abuse, misuse, misapplication, or modification not intended by WATERROWER or (b) from deterioration due to normal wear and tear.

The cost of returning the machine or parts to the WATERROWER factory or to the designated service centre shall be borne by the claimant.

The machine or parts must be packaged in such a way as to protect it/them from damage; WATERROWER shall not be liable for any damage that may occur during transportation. Shipments must be postage prepaid and the package must contain the name, address, and phone number of the claimant, a description of the problem, and proof of purchase.

WATERROWER shall return the machine or parts to the claimant at its expense (WATERROWER), except in cases where the warranty is found to be void. In the event of a void warranty claim, the costs of these inquiries, repairs and any shipping costs shall be borne by the claimant.

The WATERROWER warranty is not transferable. In the event of transfer of ownership of the machine, the warranty can also be transferred at an additional cost. WATERROWER provides a guarantee against any defective spare part received from WATERROWER or an authorised dealer for a period of THIRTY (30) DAYS after the date of shipment.

WATERROWER cannot be held liable for any direct, indirect, incidental, or special damage under this warranty, nor for any implied warranty.

The warranty described supersedes all other warranties, express or implied, including, without limitation, any implied warranty of merchantability or fitness for a particular purpose.

Some regions do not allow limitation of incidental or consequential damages. Therefore, the above limitations or exclusions may not apply to you. This warranty gives you specific legal rights and you may have other rights that vary from region to region.

For further information, frequently asked questions, troubleshooting and service inquiries, visit
www.support.decathlon.com.

Please make note of your serial number which is located on the level gauge. You will need to reference this for any service or support you may need with your VR3.

SN: _____

Store this pamphlet in a safe place for easy reference.

CONTACT US:

For service and assistance, please visit:
www.support.decathlon.fr

